

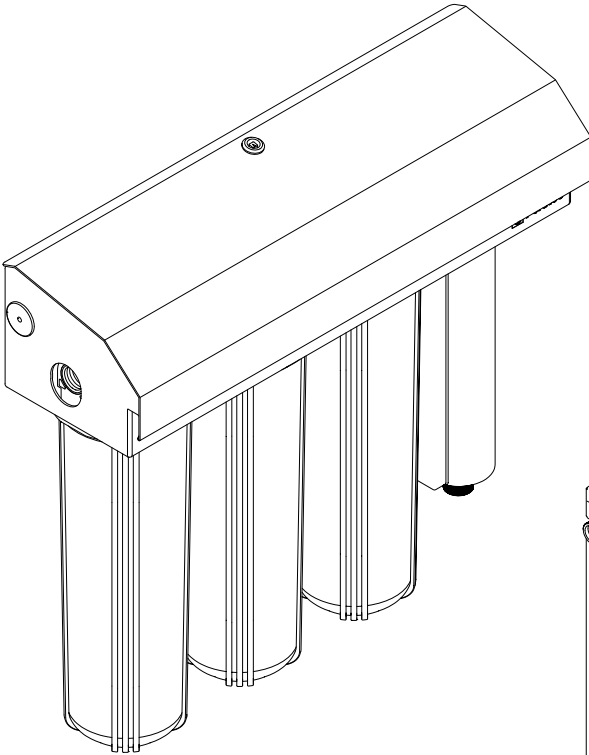

Hybrid E

*Hybrid E Reversible High Flow UV Water Treatment System
Maintenance Guide*



Registered Design & Patent Pending

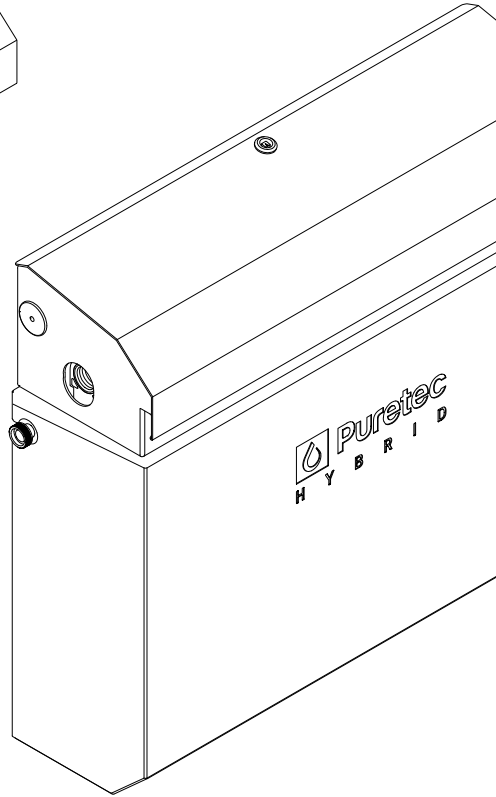

What's Inside

Puretec Customer Service	3
Introduction.....	3
Power Surge Protection.....	4
Instiallation Record.....	4
Installation Requirements.....	5
Fig. 6 - Systems Parts Diagram.....	7
Fig 7. - Radfire™ Ultraviolet Steriliser Parts Diagram.....	8
Model Information.....	9
Operation	14
Radfire™ Ultraviolet System Specifications.....	15
Replacement Parts Guide.....	16
Cartridge Replacement Procedure.....	17
Quartz Sleeve Maintenance / Replacement Procedure.....	18
Lamp Replacement Procedure.....	20
Electronic Ballast Replacement.....	22
Troubleshooting Guide	23
Warranty.....	25



Puretec Customer Service

Thank you for purchasing a Puretec Hybrid E Series System. Your system is a proven performer manufactured from quality materials and components and will give years of 'spring like' water, if maintained and installed properly.

Puretec Hybrid ultraviolet systems are designed for common rainwater. The effectiveness of a ultraviolet steriliser is dependent on the clarity of water present. If you are unsure of the clarity of your water Puretec can arrange a ultraviolet transmittance (UVT) test to verify that no further filtration is required before the Hybrid E System. Contact Puretec on 1300 140 140 (AU) or 0800 130 140 (NZ) for further information on this.

Introduction

Puretec Hybrid E Series is carefully designed, using a natural sterilisation process that's eco-friendly and chemical-free, to kill up to 99.99% of harmful bacteria in untreated water supplies. The system includes pre-filtration to ensure that particulate matter does not shield micro-organisms from ultraviolet light.

The system is designed for rainwater supplies but may be used in other applications. For use with alternative water supplies, please contact your local Puretec stockist, or call our Puretec Customer Service Helpline on 1300 140 140 (Australia) or 0800 130 140 (New Zealand).

The Puretec Hybrid E cartridges and lamp need replacing regularly to maintain optimum performance. This is a simple procedure when following the instructions provided in your maintenance guide. For replacements, contact your nearest Puretec stockist, we recommend purchasing our all-inclusive Maintenance Kit, see your maintenance guide for order codes specific to your model.

Your new Hybrid E system incorporates a failure warning feature that warns you of a lamp failure by:

1. An LED warning light
2. An audible alarm

The alarm beeping and red light flashing every 3 seconds, will indicate that the lamp is due for a change, and a blue LED light will indicate that the system is still operating correctly.

Power Surge Protection

An electrical power surge or spike can travel on the supply lines and cause serious damage to your electrical equipment. The electronic controller has a fuse (non-replaceable) to protect the circuit. The fuse is not a lightning arrester and may not protect the ultraviolet steriliser if lightning, or a very powerful surge hits the unit.

A suitable surge protection device has been provided with this product. Puretec recommends the use of a surge protector (the one supplied or otherwise) or warranty may be voided.

WARNING: The power surge protector provided, is not weatherproof & MUST be protected from water/moisture.

It would usually be sufficient for the surge protector to be installed under the eaves of a house and/or out of the weather, otherwise, it would need to be suitably protected. Ensuring the surge protector is suitably protected from water/moisture is the responsibility of the user. Alternatively, a hard-wired outdoor surge protector may be installed by a qualified electrician or an outdoor rated surge protector may also be used.

Reorder code for surge protectors: PC-SURGE

Do not use long extension leads, as they may cause substantial voltage drop and/or poor lamp performance. **We recommend the use of an RCD or earth leakage circuit breaker** on the power supply to your unit.

Installation Record

Product Information	
Distributor:	
Installer:	
Phone:	
Date Installed:	

Installation Requirements

WARNING: FOR THE CORRECT OPERATION OF THIS APPLIANCE, IT IS ESSENTIAL TO OBSERVE THE MANUFACTURER'S INSTRUCTIONS.

All Hybrid E systems should be protected from harsh environments where overexposure to salt or aggressive chemicals can occur.

- Cold water line only.
- Power supply: AC 240V | 50Hz
- Supply pressure: 300 - 875* kPa.

** Where line pressure exceeds 500 kPa, an approved pressure-limiting device must be installed to comply with Australian & New Zealand Plumbing Standards. (Ref. AS/NZS 3500.1:2021, Clause 3.3.4).*

- Ambient temperature 0 - 52 °C (protect from freezing).
- Water Supply Temperature 2 - 38 °C
- For point of entry installations, an approved dual check back flow prevention device must be installed.
- Alternative fittings may be required if the system is connected to anything other than 25 mm threads.
- Liquid sealants may be used, however, please take care to ensure the correct sealant is used. Use the appropriate amount, without any overflow or spillage.
- Ensure the water supply flow rate does not exceed the rated maximum of the Hybrid E system.
- Ensure the electrical power supply to the Hybrid E system is sufficient, allowing for other appliances that may be connected to the circuit e.g. pump. Confirm the unit is surge-protected and protected against brown-outs. If in doubt, please consult a qualified electrician.
- Use union joints at pipe connections to enable easy removal and servicing.
- Use sufficient tape/sealant to ensure an airtight seal and do not over-tighten.
- To prevent strain on the unit, heavy inlet and outlet pipes should always be supported.

A deposit build-up on the quartz sleeve may occur over time if the water being treated contains unusually high levels of dissolved solids- particularly hard water, iron,

manganese or biological organisms. The maximum recommended parameters are as follows:

Hydrogen Sulfide:	less than 0.05 mg/L
Suspended Solids:	less than 10mg/L
Manganese:	less than 0.05 mg/L
Hardness:	less than 110mg/L
Iron:	less than 0.3 mg/L
pH Range:	5 to 9

Application Warning: Minimum water characteristics must be met before the installation of the Hybrid system to ensure proper operation and continuous protection.

If stated water quality parameters are exceeded; pre-filtration is required as water of this quality can compromise the effectiveness of the ultraviolet steriliser. The filters and the sleeve should be cleaned or replaced as required to keep them in good condition.

If bacteria has been present prior to the installation of this system, we recommend flushing the pipelines with Puretec TankSafe™.

Warning: The ultraviolet steriliser should only be connected to metal pipes and/or fittings for at least 1 metre after the outlet. Never connect plastic pipes or fittings directly to the ultraviolet steriliser.

The system should not be used for any other purpose without specific referral by Puretec.

The heating of water is a result of the emittance of ultraviolet rays, if this is deemed a problem we recommend installing a temperature management valve, installed inline immediately after the system, releasing water periodically. **Ordering code is RI-TMS4.**

Installation Note: A water filter system/tap, like any product, has a limited life and may eventually fail. Sometimes failure occurs prematurely due to unforeseen circumstances. To avoid possible property damage, this product should be regularly examined for leakage and/or deterioration and replaced when necessary. A drain pan, plumbed to an appropriate drain or outfitted with a leak detector, should be used in those applications where any leakage could cause property damage, and/or the water supply should be turned off if no one is home/present.

INSTALLATION SHOULD BE COMPLETED BY QUALIFIED TRADESPEOPLE. FAULTY OPERATION DUE TO UNQUALIFIED PERSONS WILL RESULT IN VOIDED WARRANTY COVERAGE.

Fig. 1 - System Parts Diagram, Exploded View

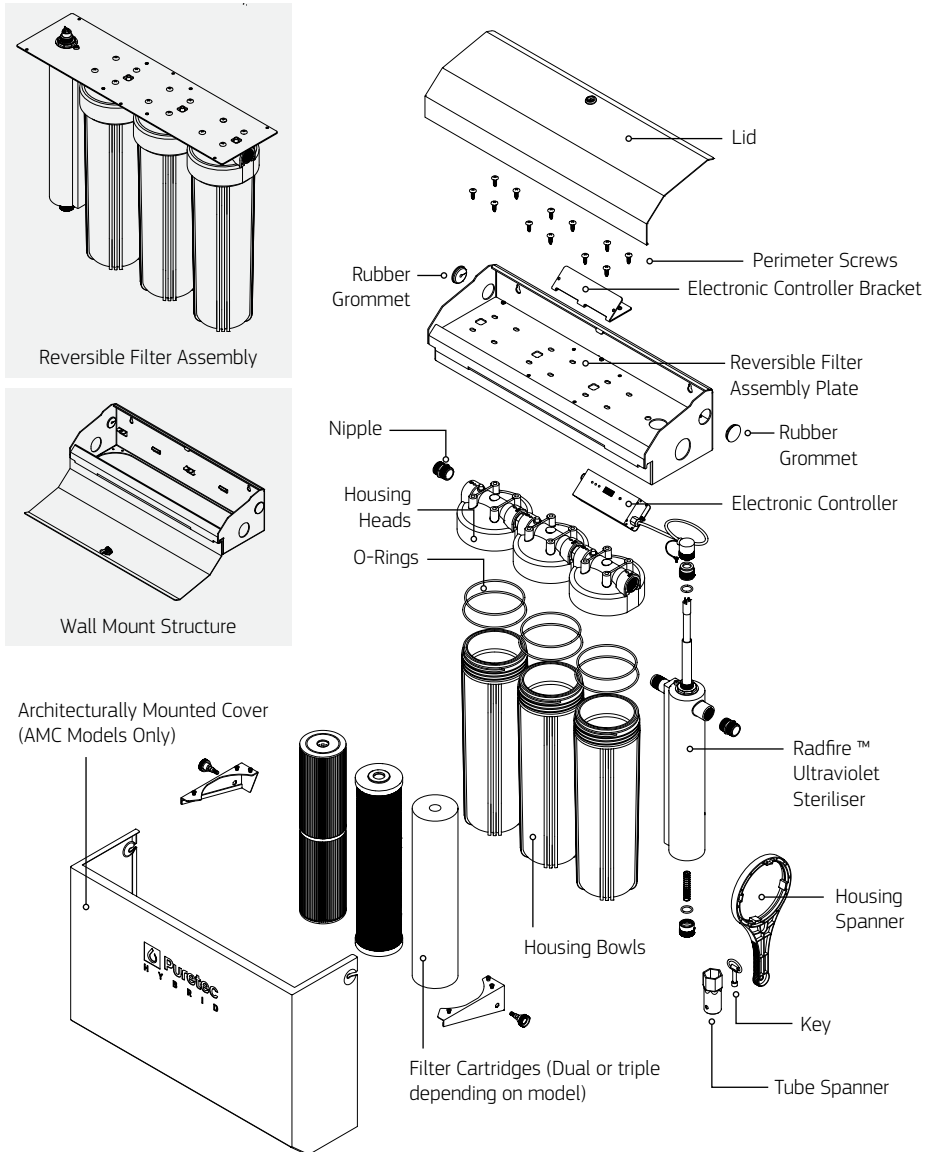
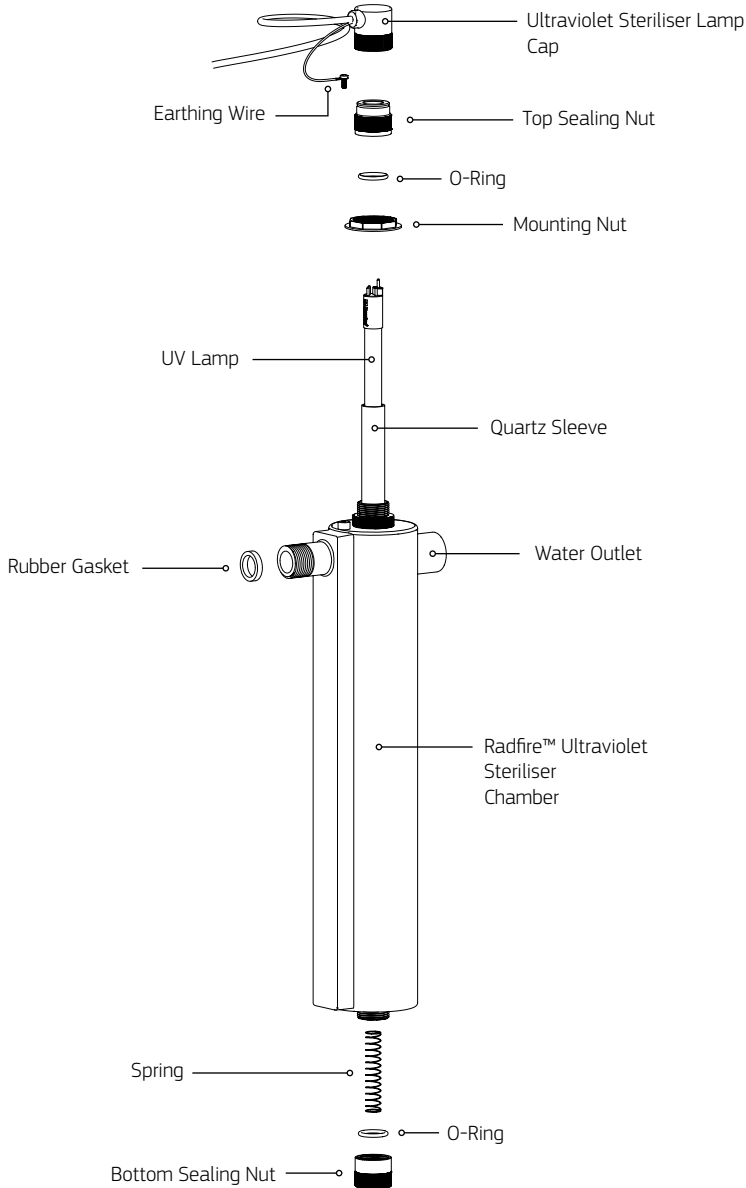

Fig. 2 - Radfire™ Ultraviolet Steriliser Parts Diagram, Exploded View



E6 Model Information

Specifications

Max. Flow Rate :	75 Lpm
Flow Rate @16mJ/cm ² :	130 Lpm
Flow Rate @30mJ/cm ² :	70 Lpm
Flow Rate @40mJ/cm ² :	54 Lpm
Dimensions:	578 mm (W) x 631 mm (H) x 241 mm (D)
Micron Rating:	5 micron [^]
Min/Max Temperature:	0 - 52°C (protect from freezing)
Water Supply Temperature:	2 - 38°C
Min/Max Pressure:	300 - 875* kPa
Connection:	1" BSP (Male) (25 mm)
Maintenance Kit Order Code:	HR-EI6 (Includes all cartridges required)
1st Stage:	PL05MP1, 10" MaxiPlus™ Pleated Sediment
2nd Stage:	DP10MP1, 10" MaxiPlus™ Dual Purpose

Note: *Where line pressure exceeds 500 kPa, an approved pressure limiting device must be installed to comply with Australian & New Zealand Plumbing Standards. ^Micron rating is nominal.

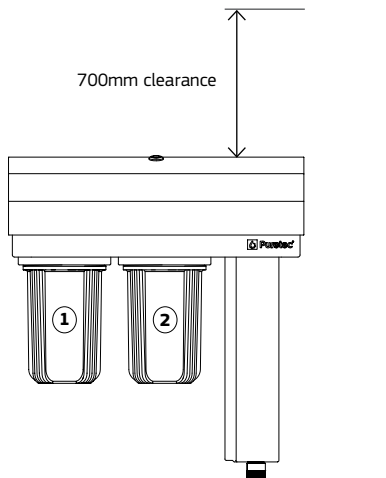

Left to right water flow shown.

E7 / E7AMC Model Information

Specifications

Max. Flow Rate :	130 Lpm
Flow Rate @16mJ/cm ² :	130 Lpm
Flow Rate @30mJ/cm ² :	70 Lpm
Flow Rate @40mJ/cm ² :	54 Lpm
E7 Dimensions:	578 mm (W) x 695 mm (H) x 241 mm (D)
E7AMC Dimensions:	578 mm (W) x 717 mm (H) x 241 mm (D)
Micron Rating:	5 micron [^]
Min/Max Temperature:	0 - 52°C (protect from freezing)
Water Supply Temperature:	2 - 38°C
Min/Max Pressure:	300 - 875* kPa
Connection:	1" BSP (Male) (25 mm)
Maintenance Kit Order Code:	HR-EI7 (Includes all cartridges required)
1st Stage:	PL05MP2, 20" MaxiPlus™ Pleated Sediment
2nd Stage:	DP10MP2, 20" MaxiPlus™ Dual Purpose

Note: *Where line pressure exceeds 500 kPa, an approved pressure limiting device must be installed to comply with Australian & New Zealand Plumbing Standards. [^]Micron rating is nominal.

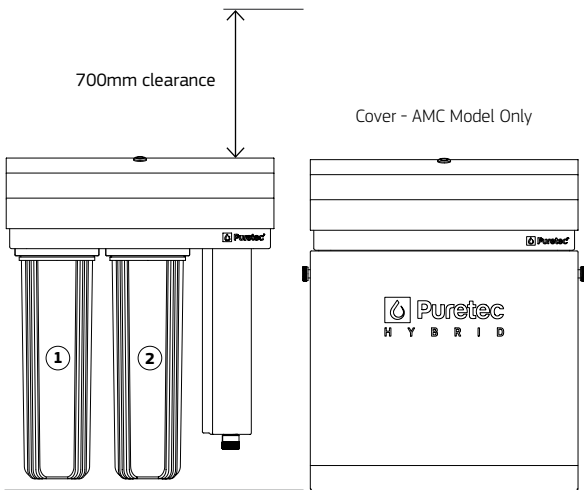

Left to right water flow shown.

E8 Model Information

Specifications

Max. Flow Rate :	75 Lpm
Flow Rate @16mJ/cm ² :	130 Lpm
Flow Rate @30mJ/cm ² :	70 Lpm
Flow Rate @40mJ/cm ² :	54 Lpm
Dimensions:	578 mm (W) x 631 mm (H) x 241 mm (D)
Micron Rating:	1 micron [^]
Min/Max Temperature:	0 - 52°C (protect from freezing)
Water Supply Temperature:	2 - 38°C
Min/Max Pressure:	300 - 875* kPa
Connection:	1" BSP (Male) (25 mm)
Maintenance Kit Order Code:	HR-E18 (Includes all cartridges required)
1st Stage:	PL20MP1, 10" MaxiPlus™ Pleated Sediment
2nd Stage:	PX01MP1, 10" MaxiPlus™ Polyspun Sediment

Note: *Where line pressure exceeds 500 kPa, an approved pressure limiting device must be installed to comply with Australian & New Zealand Plumbing Standards. [^]Micron rating is nominal.

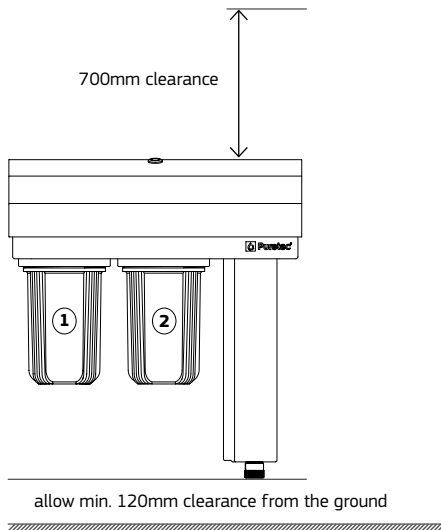

Left to right water flow shown.

E9 / E9AMC Model Information

Specifications

Max. Flow Rate :	130 Lpm
Flow Rate @16mJ/cm ² :	130 Lpm
Flow Rate @30mJ/cm ² :	70 Lpm
Flow Rate @40mJ/cm ² :	54 Lpm
E9 Dimensions:	578 mm (W) x 695 mm (H) x 241 mm (D)
E9AMC Dimensions:	578 mm (W) x 717 mm (H) x 241 mm (D)
Micron Rating:	1 micron [^]
Min/Max Temperature:	0 - 52°C (protect from freezing)
Water Supply Temperature:	2 - 38°C
Min/Max Pressure:	300 - 875* kPa
Connection:	1" BSP (Male) (25 mm)
Maintenance Kit Order Code:	HR-E19 (Includes all cartridges required)
1st Stage:	PL20MP2, 20" MaxiPlus™ Pleated Sediment
2nd Stage:	PX01MP2, 20" MaxiPlus™ Polyspun Sediment

Note: *Where line pressure exceeds 500 kPa, an approved pressure limiting device must be installed to comply with Australian & New Zealand Plumbing Standards. [^]Micron rating is nominal.

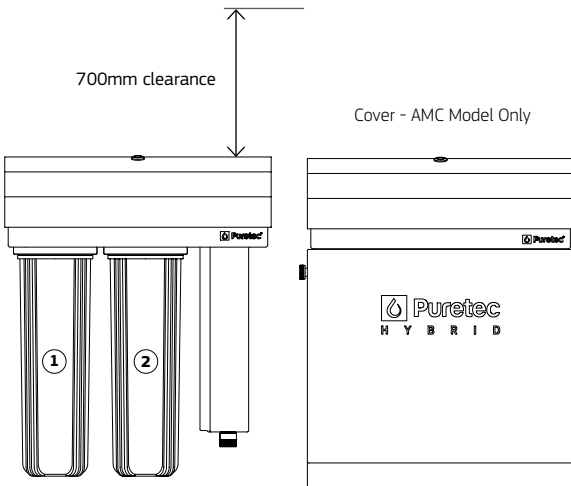

allow min. 120mm clearance from the ground

Left to right water flow shown.

E13 / E13AMC Model Information

Specifications

Max. Flow Rate :	120 Lpm
Flow Rate @16mJ/cm ² :	130 Lpm
Flow Rate @30mJ/cm ² :	70 Lpm
Flow Rate @40mJ/cm ² :	54 Lpm
E13 Dimensions:	774 mm (W) x 695 mm (H) x 241 mm (D)
E13AMC Dimensions:	774 mm (W) x 717 mm (H) x 241 mm (D)
Micron Rating:	1 micron [^]
Min/Max Temperature:	0 - 52°C (protect from freezing)
Water Supply Temperature:	2 - 38°C
Min/Max Pressure:	300 - 875* kPa
Connection:	1" BSP (Male) (25 mm)
Maintenance Kit Order Code:	HR-E13 (Includes all cartridges required)
1st Stage:	PL05MP2, 20" MaxiPlus™ Pleated Sediment
2nd Stage:	CB05MP2, 20" MaxiPlus™ Carbon Block Taste & Odour
3rd Stage:	PX01MP2, 20" MaxiPlus™ Polyspun Sediment

Note: *Where line pressure exceeds 500 kPa, an approved pressure limiting device must be installed to comply with Australian & New Zealand Plumbing Standards. ^Micron rating is nominal.

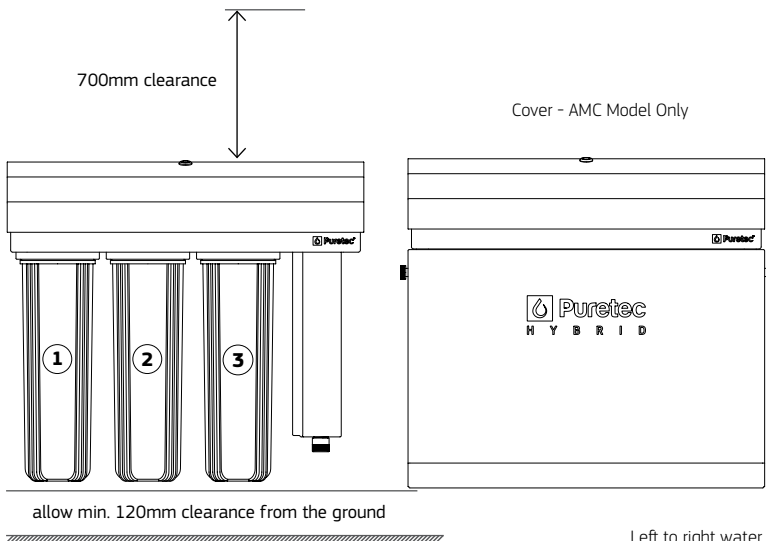

Operation

At any point after the ultraviolet lamp has been turned off allow two minutes for the lamp to reach full intensity before starting the water flow.

On a new installation, where no other form of sterilisation has been in use, we recommend flushing the pipework with a suitable sanitiser such as TankSafe™ (for dosage refer to TankSafe™ product instructions). This solution should be left in the pipework for at least an hour and preferably overnight.

The sanitising solution can be added into the water tank or if necessary added as a shock dose into the bowl of the filter housing of the Hybrid and slowly flushed through the piping. If added as a shock dose the system and pipework should be rinsed thoroughly by opening a downstream tap.

Radfire™ Ultraviolet Steriliser Operation

Before performing any work on the ultraviolet steriliser, always disconnect the power supply.

Warning: Do not look directly into ultraviolet rays emitted from the lamp as they will cause serious burns to unprotected eyes.

The treated water will seem warm for a short period at first flow. This is because the lamp emits heat when producing ultraviolet rays to kill bacteria. When turning on a tap, let the water run for a short time to purge any warm water.

Electronic Controller Operation

Countdown Timer

This timer shows the number of days remaining out of the total 365 days before the lamp reaches the end of life and should be replaced with a genuine Puretec **RL7** lamp. If the electronic controller is in temporary silence mode, the timer will show the number of days remaining in the temporary silence period of 7 days.

Total Running Time

Shows the number of days the lamp has been running since the last reset.

This will continue to increase from 365 when the electronic controller is in temporary silence mode.

Length of time button is pressed	Function	Result
< 5 seconds	In normal operation, switch display between countdown timer and total running time.	The total running time will display for 10 seconds then switch back to the countdown timer
< 5 seconds	During EC5 switch the display screen between "EC5", countdown timer and total running time. Note: See Electronic Controller Troubleshooting and Error Codes table for display code details	The screen can be switched between the error code, countdown timer and total running time.
5 - 15 seconds	Temporary silence of alarm (attempt 1-4). Warning: Silencing the alarm for a fifth time will result in the light turning off. See "EC4" for more details.	The unit will beep and show "DLAY" on display for 3 seconds, before silencing the alarm for 7 days. The fault light will remain on for the duration of the 7 days. Note: The countdown timer will begin to count downward from 7, and the total running time will continue counting up from 365. Note: The alarm will come back on and the fault light will start flashing again after the 7 day period.
15+ seconds	Total electronic controller reset. Should be completed when lamp is replaced	The unit will beep and the countdown timer will reset to 365 and the total running time will reset to 0. Additionally, the silence counter will return to 0.

Radfire™ Ultraviolet Steriliser System Specifications

Input Current:	0.5A (120V) / 0.25A (240V)
Power Output:	46W Max
U-OUT:	60V
Power Factor:	>95%
Ambient Temperature:	0 - 40°C
Ultraviolet Lamp Rated Life:	365 days

Caution: Ensure the electronic controller casing is properly earthed to avoid possible high voltage shock hazard.

Replacement Parts Guide

To maintain a high quality of purified water, the cartridges will need changing periodically (dependent on water quality and usage).

You can obtain replacement cartridges from your local Puretec dealer. To maintain performance, warranty and Australian Standards use genuine Puretec replacements.

Model	Maintenance Kit Code
HYBRID-E6	HR-EI6
HYBRID-E7 / HYBRID-E7AMC	HR-EI7
HYBRID-E8	HR-EI8
HYBRID-E9 / HYBRID-E9AMC	HR-EI9
HYBRID-E13 / HYBRID-E13AMC	HR-EI13

Replace cartridges every 6 - 12 months, depending on water quality. Ultraviolet lamps must be replaced annually in order to maintain a kill rate of up to 99.9% of bacteria.

Find out more information & where to buy your maintenance kits by scanning the QR codes below:



HR-EI6



HR-EI7



HR-EI8



HR-EI9



HR-EI13

Cartridge Replacement Procedure

To change the filter cartridges please adhere to the following procedure:

1. Turn the water supply off, and relieve the pressure by opening a downstream tap, or pressing the red pressure-relief button on the housings.
2. If the unit is an AMC model, take off the AMC (Architecturally Mounted Cover) by loosening the two black handles on the sides and sliding the cover forward.
3. Unscrew the filter bowls counterclockwise. If the bowl is difficult to undo, the housing spanner provided may be used to make it easier. Remove old cartridges and dispose of them in the correct manner.
4. Clean bowls with Puretec HC750 housing cleaner, and rinse thoroughly. Check O-rings for damage and replace if necessary.
5. Check O-ring lubrication and if necessary apply a light coating of food-grade silicone lubricant supplied in your Puretec maintenance kit (or similar).
6. Remove all packaging from new filter cartridges and insert them into housing bowls making sure cartridges are properly seated over the spigot in the base of the bowls. Remember to record the model number of the cartridges used & install date.
7. Hold bowls upright while screwing in the housings. Make certain that the spigot in the housing heads is located centrally to the cartridges to make a good seal. Tighten the bowls until firm. **HAND TIGHTEN ONLY. DO NOT OVER TIGHTEN**
8. If your unit is an AMC model, resecure the cover on the unit.
9. Open a downstream tap to allow air to be released and gently open the water supply allowing all air to be purged.
10. Allow the water to run for 1 - 2 minutes to flush the system.
11. Close the downstream tap and check the Hybrid system for leaks.

Note: Flush the system for 1 - 2 minutes after any period of non-use more than 2 weeks. For a period of non-use of 6 months or more, it may be necessary to replace the cartridges.

Quartz Sleeve Maintenance / Replacement Procedure

To ensure a high sterilising rate with the best water quality, check the sleeve regularly (about every 3 months depending on quality of water source) to see if there is a build-up of dirt or substances.

Allow the unit to cool before servicing.

Before performing any work on the ultraviolet steriliser, always disconnect the power supply.



1. Turn off the power and water to the unit and release the water pressure (using the red buttons above the unit's filters).
2. Unlock and open the lid. If your unit is an AMC Model, remove the AMC (Architecturally Mounted Cover).

3. Disconnect the black ultraviolet steriliser lamp cap from the top sealing nut on the ultraviolet sterilisation chamber by gently lifting it upwards. Carefully unplug the lamp from the cap.

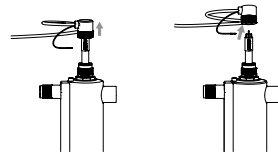

4. Slowly remove the ultraviolet lamp from the chamber.
5. Unscrew and remove the top sealing nut on the top of the chamber. Place to the side.
6. Next, remove the bottom sealing nut from the bottom of the stainless steel chamber.

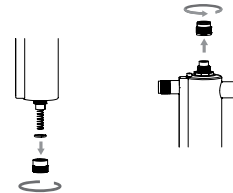

Important: Be aware water will be discharged from the chamber, and the spring will likely fall to the ground.

Important: The quartz sleeve may also come through the base of the chamber, hold the quartz sleeve to prevent it from sliding out and remove the bottom O-ring. Place the spring to the side, it will be needed later.

7. Slide the quartz sleeve out of the top of the chamber.
8. Clean the quartz sleeve with Puretec SC1000 sleeve cleaner if necessary, or replace if damaged, a new quartz sleeve will be provided in the maintenance kit.

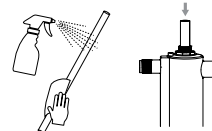

- Slide the quartz sleeve into the top of the chamber and carefully slide down through the bottom opening. Place the bottom O-ring on the quartz sleeve and while still holding the quartz sleeve from the top, screw the bottom sealing nut onto the chamber.

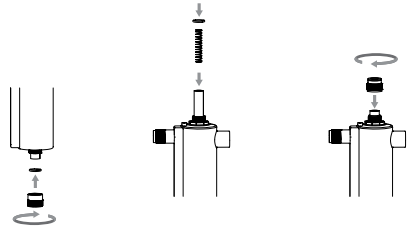

- Gently tap the sleeve to ensure that it's sitting firmly the bottom sealing nut.
- Place the top O-ring on the top of the sleeve, insert the spring (allowing it to slide to the bottom of the quartz sleeve) and screw on the top sealing nut.

- Slowly insert the ultraviolet lamp into the chamber through the hole of the top sealing nut. Connect the black ultraviolet steriliser lamp cap to the pins on the lamp. Do not let go of the lamp until the lamp is securely connected to the lamp cap. Never touch the quartz (glass) and lamp surface as marks or fingerprints may interfere with ultraviolet transmission. If lamp is soiled, please clean lamp with an alcohol-based cleaner.

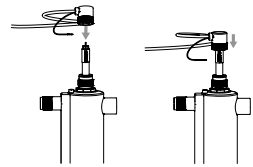

- Secure the lamp cap on the top sealing nut.
- Turn the water on, and let the water flow through – opening a tap downstream to flush unit for 3-5 minutes. Then check the system thoroughly for leaks.

- Plug in the electronic controller to a surge-protected power source and turn on.

Note: For initial use, wait an additional 2-3 minutes to release air and impurities from the system. Water will not be protected by ultraviolet sterilisation until this is complete.

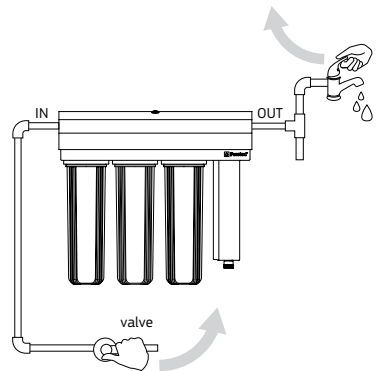

- Re-check the unit for leaks after 1 hour.
- Close and lock the lid, if your unit is an AMC Model reinstall the cover. Your cabinet comes with a key for your convenience. Please store it safely.

Note: Lost or misplaced keys are not covered by warranty.

Lamp Replacement Procedure

Prior to performing any work on the ultraviolet steriliser, always disconnect the power supply first.

1. Turn the water off and release the water pressure by opening a downstream tap, or using the red pressure relief buttons on the system.
2. Unlock and open the cover. Disconnect the black ultraviolet steriliser lamp cap by lifting it upwards. Grip the end of the lamp and carefully disconnect from the lamp cap.
3. Slowly remove the old lamp from the chamber. Dispose of it appropriately.
4. Remove the packaging on the new lamp, do not touch the glass. Slowly insert into the chamber through the top hole of the top sealing nut. Connect the ultraviolet steriliser lamp cap to the pins on the lamp. Do not let go of the lamp until the lamp is connected to the lamp cap.

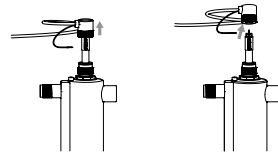

Important Note: Never touch the quartz (glass) and lamp surface as marks or fingerprints may interfere with ultraviolet transmission. If lamp is soiled, please clean lamp with alcohol-based cleaner.

5. Secure the ultraviolet steriliser lamp cap on the top sealing nut. Turn the water on, let the water flow through – opening a tap downstream to flush the unit for 3-5 minutes. Then check the system thoroughly for leaks.
6. Plug in the electronic controller into a surge-protected power source, the RED LED will be illuminated (when the lamp life timer is reset in step 7 the LED will turn blue).

Note: For initial use, wait an additional 2-3 minutes to release air and impurities from the system. Water will not be protected by ultraviolet sterilisation until this is complete.

7. Press and hold the silver button for 15 seconds, an audible "beep" will sound indicating that the lamp life timer has been reset to 365 days.

8. Re-check the unit for leaks after 1 hour.

9. Using the key provided close and lock the lid.

Note: Your cabinet comes with a key for your convenience. Please store it safely.

Note: Lost or misplaced keys are not covered by warranty.

10. We recommend replacing the ultraviolet lamp annually to ensure a high sterilising rate with best water quality. Unless servicing, always keep the ultraviolet lamp on, as power fluctuation will shorten the service life of the ultraviolet lamp.

Electronic Controller Replacement

1. Isolate the water supply to avoid contamination downstream of the appliance.
2. Turn the power socket off at the switch where the electronic controller is connected.
3. Disconnect the original electronic controller from the power, by removing the plug from the power socket.
4. Feed the power cable through the bracket (via the rubber grommet).
5. Unscrew the retaining screw connecting the yellow earthing wire to the ultraviolet sterilisation chamber.
6. Disconnect lamp from the ultraviolet steriliser lamp cap. The lamp can remain sitting on the spring inside the ultraviolet sterilisers sleeve
7. Unfasten the 2 mounting screws that hold the electronic controller on the electronic controller bracket, and set the screws aside.
8. Remove the old electronic controller, and discard in accordance with local guidelines
9. Attach the new electronic controller to the bracket using the 2 mounting screws
10. Connect the ultraviolet steriliser lamp cap to the lamp pins.
11. Securely fasten the earth lead to the ultraviolet sterilisation chamber with the retaining screw.
12. Feed the power cable through the bracket (via the rubber grommet).
13. Plug the inlet power cable to a fixed power socket
Note: Surge protection is required, use of extension leads or generators will impact performance
14. Switch power on at the socket. Allow 2 minutes for the lamp to reach full intensity
15. Return water to service.
16. Open a tap downstream of system and allow the system to flush for 3 - 5 minutes.

Troubleshooting Guide

Symptoms	Possible Cause	Possible Solution
Electronic controller or breaker repeatedly trips.	<ol style="list-style-type: none"> 1. Connection between lamp and lamp plug is wet. 2. Short-circuit in the electrical assembly. 	<ol style="list-style-type: none"> 1. Clean and dry lamp pins and lamp plug, check unit for leaks or condensation. 2. Replace electronic controller.
Leak at inlet or outlet.	<ol style="list-style-type: none"> 1. Threaded pipe fittings are leaking. 2. Cracked heads. 	<ol style="list-style-type: none"> 1. Clean threads, reseal with Teflon tape and retighten. 2. Replace heads.
Leak detected from ultraviolet sterilisation chamber area.	<ol style="list-style-type: none"> 1. Condensation of moist air on cold chamber (slow accumulation). 2. O-ring damaged, deteriorated or incorrectly installed. 3. Lamp/sleeve assembly not properly installed (too tight or not tight enough). 4. Quartz sleeve is damaged. 	<ol style="list-style-type: none"> 1. Control humidity or relocate unit. 2. Inspect and replace if deteriorated. Check O-rings are in place. 3. Tighten assembly hand-tight. 4. Visually inspect the quartz sleeve and replace if damaged.
System is operating but water tests reveal bacterial contamination.	<ol style="list-style-type: none"> 1. Equipment downstream of the ultraviolet sterilisation system is acting as a breeding ground for pathogens. 2. Pathogens are residing in the distribution lines post-ultraviolet sterilisation. 3. Lamp reached the maximum lamp life. 	<ol style="list-style-type: none"> 1. Ensure ultraviolet sterilisation system is the last piece of treatment equipment. Ensure all distribution lines have been disinfected. 2. Remove any pipe dead-ends and flush with chlorine. 3. Replace the lamp on or before the lamp counter reaches 0.
Lamp timer does not read anything.	<ol style="list-style-type: none"> 1. Unit is unplugged. 2. No power at AC power outlet. 3. Power cord is damaged. 4. Power surge caused damage to electrical assembly. 	<ol style="list-style-type: none"> 1. Plug unit into AC power outlet. 2. Replace fuse or reset breaker. 3. Replace electronic controller. 4. Replace electronic controller.
Leak detected at filters.	<ol style="list-style-type: none"> 1. O-ring damaged, deteriorated or incorrectly installed. 2. O-rings dry. 3. Filter cartridge not centered. 	<ol style="list-style-type: none"> 1. Remove the sump, wipe the O-ring and threads clean. Ensure the O-ring is fitted properly, then reinstall. 2. Lubricate the O-rings with suitable sealant. 3. Remove sump, check for cartridge damage, and re-assemble ensuring cartridge is centered.

In the event of any other breakdown, please call Puretec on 1300 140 140 (AU) 0800 130 140 (NZ).

Electronic Controller Troubleshooting and Error Codes

Display	Audible Alarm	Red LED	Blue LED	Electronic Controller / Lamp Status	Possible Cause	Possible Solution
EC1	2 Beeps every 4 seconds. Note: Cannot be silenced.	2 flashes every 4 seconds.	Off	Off	Missing lamp or no lamp detected.	Check lamp is connected.
EC2	1 beep every 3 seconds.	1 flash every 3 seconds.	On	On	Lamp is at end of life, countdown timer has reached 0.	Replace the lamp.
EC3	2 beeps every 4 seconds. Note: Cannot be silenced.	2 flashes every 4 seconds.	Off	Off	Fault detected with lamp or electronic controller.	Replace the lamp and/or replace the electronic controller.
EC4	2 Beeps every 4 seconds. Note: Cannot be silenced any more.	2 flashes every 4 seconds.	Off	Off	Maximum silences reached (cannot be silenced more than 4 x 7 days).	Replace the lamp and reset the electronic controller.
EC5	Off	On	On	On	Successful temporary silence. Alarm will be silenced for the next 7 days. Note: This cannot be done more than 4 times.	Caution: Unit on temporary silence. Replace the lamp and reset electronic controller.

Warning: When the end of life (EC2) is reached, it can be temporarily silenced for 7 days, up to 4 times only. After that, it will not silence again.

Warranty

Any claim under this warranty must be made within 3 years, with an additional 2 year warranty for AMC Models from the date of purchase of the product. This product is warranted to be free of defect of material and workmanship for 3 and 5 years respectively from date of purchase.

3 year warranty is 1 year parts and labour plus 2 years parts only. Excludes consumables.

AMC Models 5 year warranty is 1 year parts and labour, plus 4 years parts only, the electronic controller is 3 years only. Excludes consumables.

Puretec is renowned for its quality and after-sales support so if you have any issues please call 1300 140 140 (AU) or 0800 130 140 (NZ). To make a warranty claim, contact us directly or the place of original purchase. All costs relating to a warranty claim must be approved by Puretec prior to any work being carried out.

Puretec will pay your reasonable, direct expenses of claiming under this warranty. You may submit details and proof of your expense claim to place of purchase for consideration.

The warranty only applies if the product was used and/or installed in accordance with the user guide and/or installation instructions. This warranty is given in lieu of all other express or implied warranties and manufacturer shall in no circumstance be held liable for damages consequential or otherwise or delays caused or faulty manufacturing except as excluded by law.

Applicable to all above, is that the warranties need to be approved by Puretec to ensure product was not incorrectly used, installed or claimed. False and incorrect claims will be pursued at Puretec's discretion, including chargeable inspection and labour costs incurred.

All installation and service work should be completed by qualified tradespeople. Faulty operation due to unqualified persons will result in voided warranty coverage.

Warranty/Australia

This warranty is given by Puretec Pty Ltd, ABN 44 164 806 688, 37-43 Brodie Road, Lonsdale SA 5160, telephone no. 1300 140 140 and email at sales@puretec.com.au.

This warranty is provided in addition to other rights and remedies you have under law: Our goods come with guarantees which cannot be excluded under the Australian Consumer Law. You are entitled to replacement or refund for a major failure and to compensation for other reasonably foreseeable loss or damage. You are also entitled to have the goods repaired or replaced if the goods fail to be of acceptable quality and the failure does not amount to a major failure.

Warranty/New Zealand

This warranty is given by Puretec NZ LP, Reg. No 50081773, 178A Savill Drive, Favona, 2024, New Zealand, telephone no. 0800 130 140 and email at sales@puretec.co.nz.

This warranty is provided in addition to other rights and remedies you have under law: Our goods come with guarantees which cannot be excluded under the Consumer Guarantees Act. You are entitled to replacement or refund for a major failure and to compensation for other reasonably foreseeable loss or damage. You are also entitled to have the goods repaired or replaced if the goods fail to be of acceptable quality and the failure does not amount to a major failure.

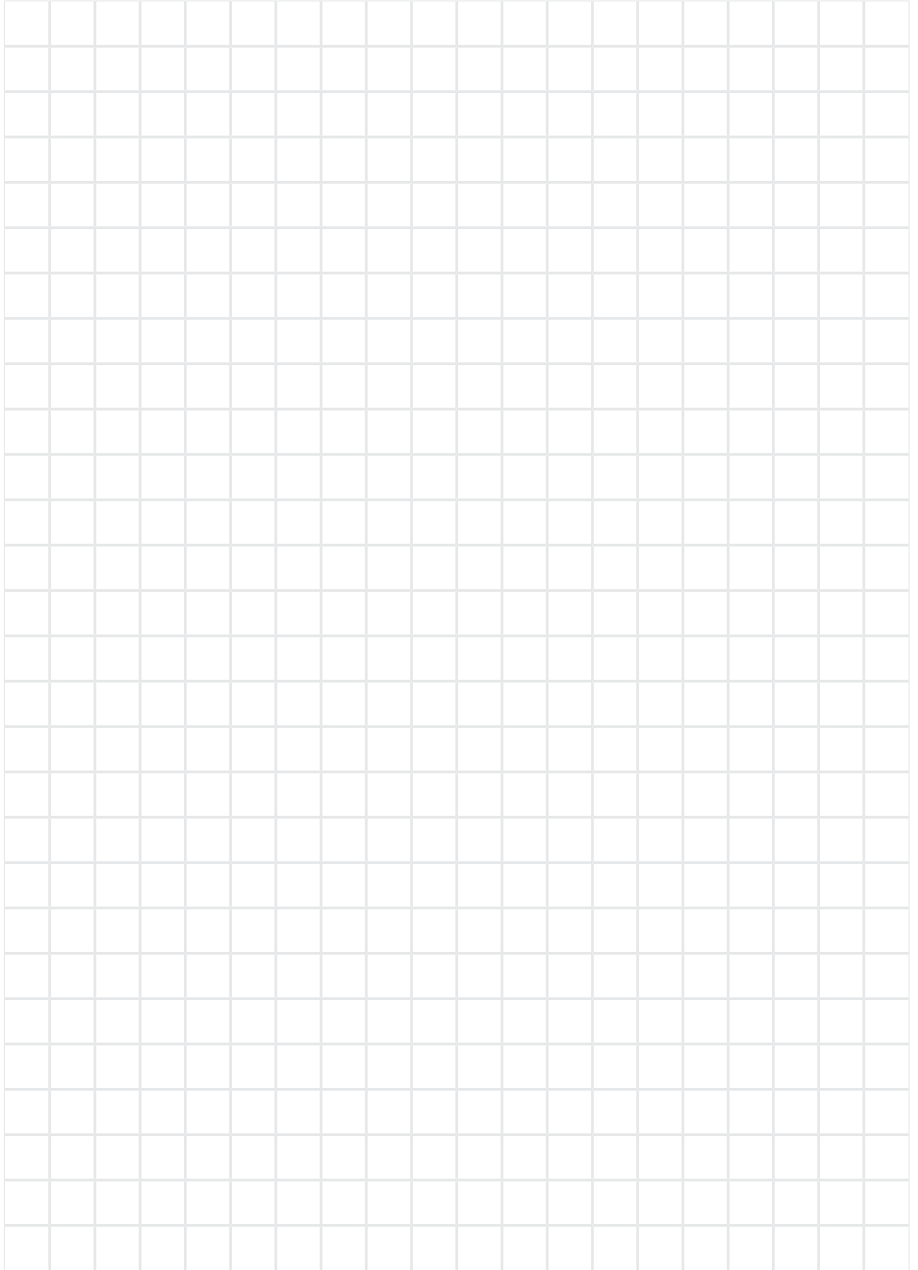



Australia

P 1300 140 140

E sales@puretecgroupp.com

W puretec.com.au

New Zealand

P 0800 130 140

E sales@puretecgroupp.com

W puretec.co.nz