

DTRON

SUBMERSIBLE PUMPS





TECHNICAL DATA

Flow rate maximum: 7,5 m³/h

Head up to: 45 m

Maximum immersion depth: 7/12 m

Type of pumped liquid: Clean, free from solid or abrasive substances, non-viscous, non-aggressive, non-crystallized and chemically neutral

Free passage: 2 mm

Minimum suction depth: 110 mm

Minimum level of water: 35 mm

Liquid temperature range: from +0°C to +50°C

Minimum and maximum ambient temperature: <0°C / +50°C

Maximum immersion depth: 15 m

Set cut-in: 2,4 bar (±0,2)

Flanges, thread: Thread 1" 1/4

Pump maximum diameter: 185 mm

Impeller/s material: Technopolymer/ AISI 304 stainless steel

Maximum number of starts: 60/h

Non-stop service: yes

Protection class: IP 68

Motor insulation class: F

Power cable (m) and plug: 10/15 m with plug

Single phase power input: 230 V 50 Hz

Possible type of installation: Fixed, horizontal or vertical. Submerged or semi-submerged. It can be installed on the surface, under the water level, or outside in a vertical position with the DOC68 accessory (supplied separately).

Special versions on request:

X version with suction kit for suction at a higher level.

Version for drinking water certified WRAS, ACS, NSF 61 and 372.

Surface version (the DOC68 accessory is required)

Certification:

WRAS, ACS, NSF 61 and 372 (only model for drinking water)

DTron2 is a 7" submersible electronic multi-impellers pump for clean water designed for use in wells and tanks. It can be used submerged, partially submerged or on the surface (with the appropriate accessory). It is suitable for use in domestic and residential environments for pressurization, rainwater reuse, gardening and irrigation activities. The pump can be installed even horizontally. It is also available in version X with 1" inlet and kit X which includes 1 meter suction hose and float to prevent the suction of impurities from the bottom. The entire pump is classified IP 68, with the DOC68 accessory (supplied separately) it becomes an IP 68 surface pump that can be used under the level of the water. On request a certified version for drinking water is available. The expansion vessel is integrated, no external expansion vessel is required.

CONSTRUCTION FEATURES OF THE PUMP

Technopolymer pump body to resist corrosion and oxidation. Integrated check valve. Integrated debris filter. Overpressure valve to resist to the formation of ice in the piping and to protect from water hammer. On the pump body there is a air-vent valve that improves priming during the first installation or in the event of emptying the tank/well. Technopolymer handle to move the pump. Integrated 0,04 liter expansion vessel sized to prevent the pump from cycling in the event of small leakages and to compensate in case of water hammer. No maintenance or recharging is required for the integrated vessel. The coupling between the three impellers in technopolymer, the floating ring and the smoothing disc both in stainless steel allow a limited wear of the hydraulics. Suction height can be adjusted using the appropriate accessory (included): 3,5 - 4 - 6 or 8 cm.

CONSTRUCTION FEATURES OF THE MOTOR

Asynchronous submersible water cooling motor. The hydraulic side of the motor shaft is in AISI 303 stainless steel. Double mechanical seal in oil chamber ensure the pump watertight. Capacitor and integrated anti-overheating motor for thermal protection. Quick coupling/release cable to facilitate installation inside tanks. Anti tear-off power cable connection.

FEATURES OF THE ELECTRONIC

The electronic operation allows the pump to start and stop autonomously by the system requirements and protects against the dry run. NFC (Near Field Communication) pocket for the use of a floater sensor (supplied separately) which can be connected without opening the pump and so maintaining a watertight seal.

DTRON 2

SUBMERSIBLE PUMPS

MATERIALS

N°	PARTS	MATERIALS
1	INSERT	BRASS
2	COVER	TECHNOPOLYMER
3	HANDLE	TECHNOPOLYMER
4	CHECK VALVE	TECHNOPOLYMER/NBR/FERRITE/AISI302
5	OR	NBR
6	OVERPRESSURE VALVE	TECHNOPOLYMER/BRASS
7	VESSEL WITH SPRING AND MEMBRANE	TECHNOPOLYMER/AISI304/EPDM70
8	PCB/CAPACITOR	--
9	PRESSURE SWITCH	TECHNOPOLYMER/BRASS
10	VENTING VALVE	TECHNOPOLYMER/AISI420/NBR
11	MOTOR SLEEVE	AISI 304
12	MOTOR SHAFT	AISI 303
13	DOUBLE MECHANICAL SEALS	RESIN IMPREGNATED CARBON/AISI304/AISI302/NBR
14	OR	NBR
15	OR	NBR
17	MOTOR BODY	TECHNOPOLYMER
18	IMPELLER	TECHNOPOLYMER/AISI304
19	DIFFUSER	TECHNOPOLYMER
20	PUMP BODY	TECHNOPOLYMER
21	FILTER	TECHNOPOLYMER

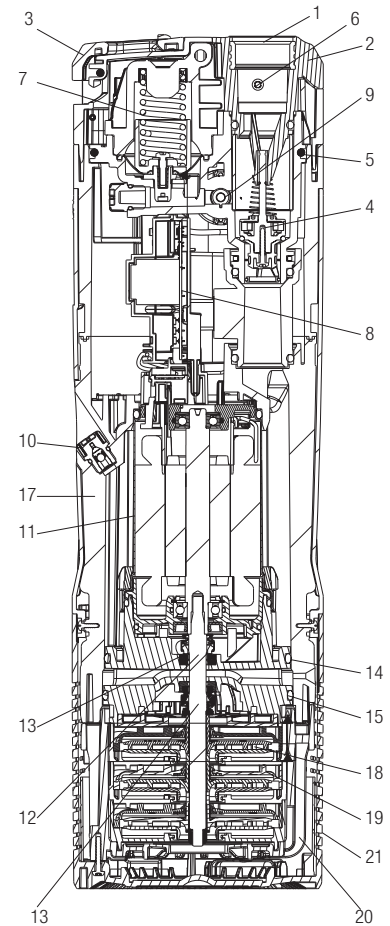

DTRON 2

SUBMERSIBLE PUMPS

PERFORMANCE AT 50 HZ

MODEL	ELECTR. DATA		HYDRAULIC DATA															
	P2 NOMINAL		Q=m³/h	0	0,7	1,2	1,8	2,4	3	3,6	4,2	4,8	5,4	6	6,3	6,6	7,3	7,5
	kW	HP	Q=l/min	0	11	20	30	40	50	60	70	80	90	100	105	110	122	125
DTRON2 35/90	0,52	0,7	H (mt)	37,0	35,9	35,0	33,0	30,0	26,7	22,7	18,5	13,4	7,6	0,6				
DTRON2 45/90	0,6	0,8		45,0	43,0	41,2	38,0	34,2	29,7	24,7	20,0	15,0	9,0	2,5	0,6			
DTRON2 35/120	0,6	0,8		38,0	37,6	36,3	34,0	31,5	28,9	26,0	23,2	20,0	16,3	12,0	9,8	7,5	2,2	0,7
DTRON2 X 35/90	0,52	0,7		37,0	35,9	35,0	33,0	30,0	26,7	22,7	18,5	13,4	7,6	0,6				
DTRON2 X 45/90	0,6	0,8		45,0	43,0	41,2	38,0	34,2	29,7	24,7	20,0	15,0	9,0	2,5	0,6			
DTRON2 X 35/120	0,6	0,8		38,0	37,6	36,3	34,0	31,5	28,9	26,0	23,2	20,0	16,3	12,0	9,8	7,5	2,2	0,7

ELECTRICAL DATA AND DIMENSIONS

MODEL	ELECTRICAL DATA					A	Ø D	H	DNM	PACKING DIMENSIONS			PACKING VOLUME m³	Q.TY X PALLET	WEIGHT Kg
	POWER INPUT 50 Hz	P1 kW	P2 NOMINAL		In A					L/A	L/B	H			
			kW	HP											
DTRON2 35/90	1 x 220-240 V ~	0,75	0,52	0,7	3,4	185	1" 1/4	611	32	740	230	300	0,05106	15	11,4
DTRON2 45/90	1 x 220-240 V ~	0,93	0,6	0,8	4,2	185	1" 1/4	611	32	740	230	300	0,05106	15	11,4
DTRON2 35/120	1 x 220-240 V ~	0,9	0,6	0,8	4	185	1" 1/4	611	32	740	230	300	0,05106	15	11,4
DTRON2 X 35/90	1 x 220-240 V ~	0,75	0,52	0,7	3,4	185	1" 1/4	611	32	740	230	300	0,05106	15	11,5
DTRON2 X 45/90	1 x 220-240 V ~	0,93	0,6	0,8	4,2	185	1" 1/4	611	32	740	230	300	0,05106	15	11,5
DTRON2 X 35/120	1 x 220-240 V ~	0,9	0,6	0,8	4	185	1" 1/4	611	32	740	230	300	0,05106	15	11,5

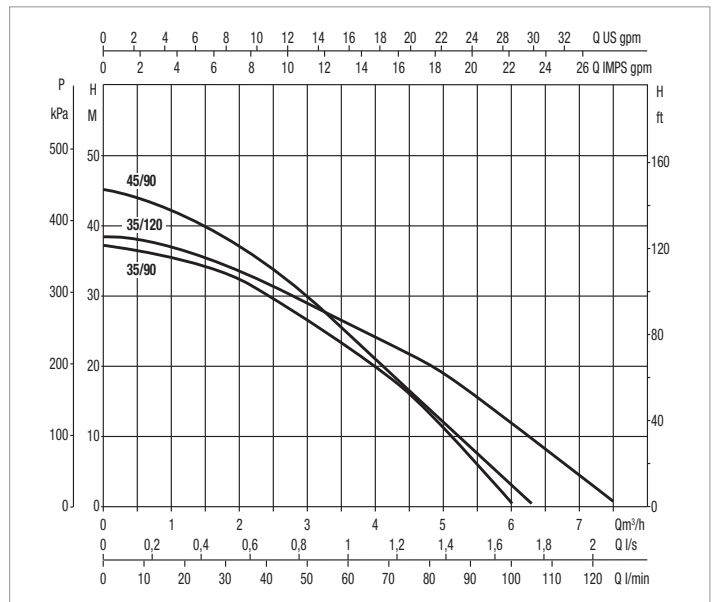
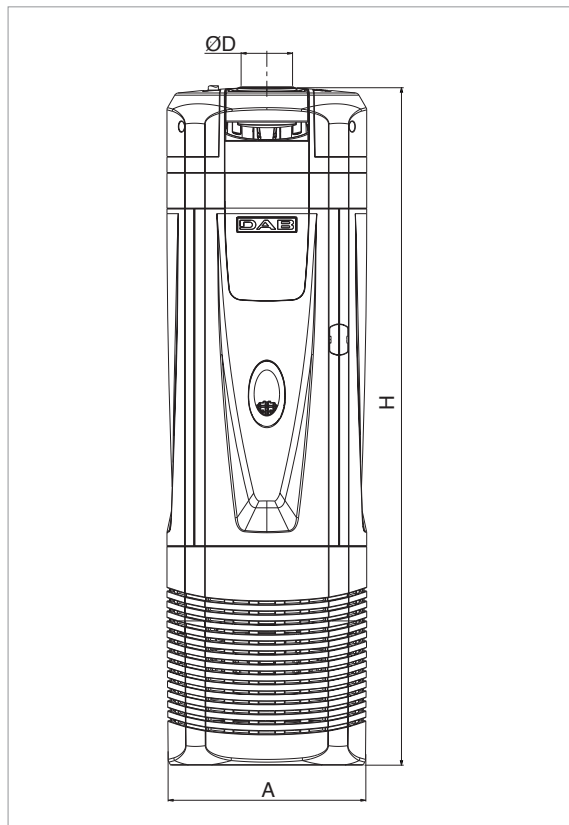

The performance curves are based on kinematic viscosity values = 1 mm²/s and density equivalent to 1000 kg/m³. Curve tolerance according to ISO 9906.

DTRON 3

SUBMERSIBLE PUMPS



TECHNICAL DATA

Flow rate maximum: 7,5 m³/h

Head up to: 45 m

Maximum immersion depth: 7/12 m

Type of pumped liquid: Clean, free from solid or abrasive substances, non-viscous, non-aggressive, non-crystallized and chemically neutral

Free passage: 2 mm

Minimum suction depth: 110 mm

Minimum level of water: 35 mm

Liquid temperature range: from +0°C to +50°C

Minimum and maximum ambient temperature: <0°C / +50°C

Maximum immersion depth: 15 m

Set cut-in: 2,4 bar (±0,2)

Flanges, thread: Filettata da 1" 1/4

Pump maximum diameter: 185 mm

Impeller/s material: Technopolymer/ AISI 304 stainless steel

Maximum number of starts: 60/h

Non-stop service: yes

Protection class: IP 68

Motor insulation class: F

Power cable (m) and plug: 10/15 m with plug

Single phase power input: 230 V 50 Hz

Possible type of installation: Fixed, horizontal or vertical. Submerged or semi-submerged. It can be installed on the surface, under the water level, or outside in a vertical position with the DOC68 accessory (supplied separately).

Special versions on request:

X version with suction kit for suction at a higher level.

Version for drinking water certified WRAS, ACS, NSF NSF 61 and 372.

Surface version (the DOC68 accessory is required)

Certification:

WRAS, ACS, NSF 61 and 372 (only model for drinking water)

DTron3 is a 7" submersible electronic multi-impellers pump for clean water designed for use in wells and tanks. It can be used submerged, partially submerged or on the surface (with the appropriate accessory). It is suitable for use in domestic and residential environments for pressurization, rainwater reuse, gardening and irrigation activities. The pump can be installed even horizontally. Equipped with PLC (PowerLine Communication) technology which allows to communicate with the external controller Com Box supplied as standard. The pump is also available in version X with 1" inlet and kit X which includes 1 meter suction hose and float to prevent the suction of impurities from the bottom. The entire pump is classified IP 68, with the DOC68 accessory (supplied separately) it becomes an IP 68 surface pump to be used under the level of the water. On request a certified version for drinking water is available. Integrated expansion vessel, no additional expansion vessel is required.

CONSTRUCTION FEATURES OF THE PUMP

Technopolymer pump body to resist corrosion and oxidation. Integrated check valve. Integrated debris filter. Overpressure valve to resist to the formation of ice in the piping and to protect from water hammer. On the pump body there is a air-vent valve that improves priming during the first installation or in the event of emptying the tank/well. Technopolymer handle to move the pump. Integrated 0,04 liter expansion vessel sized to prevent the pump from cycling in the event of small leakages and to compensate in case of water hammer. No maintenance or recharging is required for the integrated vessel. The coupling between the three impellers in technopolymer, the floating ring and the smoothing disc both in stainless steel allow a limited wear of the hydraulics. Suction height can be adjusted using the appropriate accessory (included): 3,5 - 4 - 6 or 8 cm.

CONSTRUCTION FEATURES OF THE MOTOR

Asynchronous submersible water cooling motor. The hydraulic side of the motor shaft is in AISI 303 stainless steel. Double mechanical seal in oil chamber ensuring the pump watertight. Capacitor and integrated anti-overheating motor for thermal protection. Quick coupling/release cable to facilitate installation inside tanks. Anti tear-off power cable connection.

FEATURES OF THE ELECTRONIC

The electronic operation allows the pump to start and stop autonomously, by the system requirements and protects against dry run. NFC (Near Field Communication) pocket for the use of a float sensor (supplied separately) connectable without opening the pump. Thanks to PLC communication technology, the pump transmits data throughout the power line. The controller Com Box (included) allows to set the cut-in pressure and to control the alarms. The ANTI-CYCLING protection intervenes in case of leakages in the systems.

DTRON 3

SUBMERSIBLE PUMPS

MATERIALS

N°	PARTS	MATERIALS
1	INSERT	BRASS
2	COVER	TECHNOPOLYMER
3	HANDLE	TECHNOPOLYMER
4	CHECK VALVE	TECHNOPOLYMER/NBR/FERRITE/AISI302
5	OR	NBR
6	OVERPRESSURE VALVE	TECHNOPOLYMER/BRASS
7	VESSEL WITH SPRING AND MEMBRANE	TECHNOPOLYMER/AISI304/EPDM70
8	PCB/CAPACITOR	--
9	PRESSURE SENSOR	TECHNOPOLYMER/BRASS
10	FLOW SENSOR	TECHNOPOLYMER
11	VENTING VALVE	TECHNOPOLYMER/AISI420/NBR
12	MOTOR SLEEVE	AISI 304
13	MOTOR SHAFT	AISI 303
14	DOUBLE MECHANICAL SEALS	RESIN IMPREGNATED CARBON/AISI304/AISI302/NBR
15	OR	NBR
17	OR	NBR
18	MOTOR BODY	TECHNOPOLYMER
19	IMPELLER	TECHNOPOLYMER/AISI304
20	DIFFUSER	TECHNOPOLYMER
21	PUMP BODY	TECHNOPOLYMER
22	FILTER	TECHNOPOLYMER

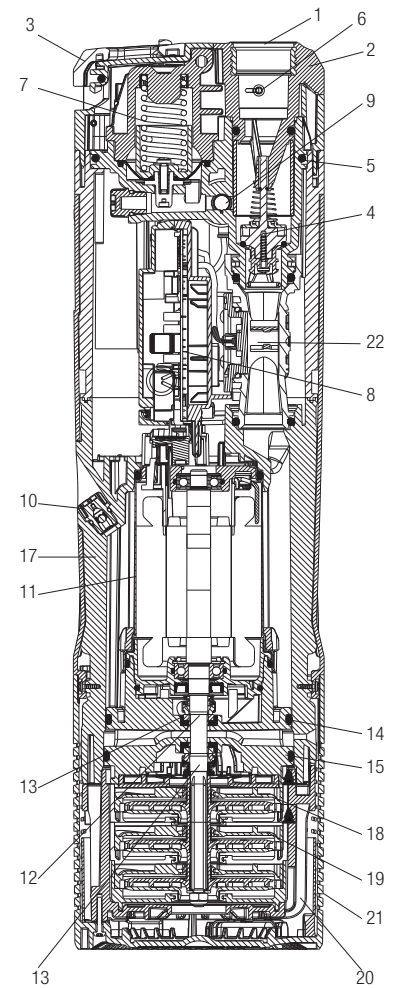

DTRON 3

SUBMERSIBLE PUMPS

PERFORMANCE AT 50 HZ

MODEL	ELECTR. DATA		HYDRAULIC DATA															
	P2 NOMINAL		Q=m³/h	0	0,7	1,2	1,8	2,4	3	3,6	4,2	4,8	5,4	6	6,3	6,6	7,3	7,5
	kW	HP	Q=l/min	0	11	20	30	40	50	60	70	80	90	100	105	110	122	125
DTRON3 35/90	0,52	0,7	H (mt)	37,0	35,9	35,0	33,0	30,0	26,7	22,7	18,5	13,4	7,6	0,6				
DTRON3 45/90	0,6	0,8		45,0	43,0	41,2	38,0	34,2	29,7	24,7	20,0	15,0	9,0	2,5	0,6			
DTRON3 35/120	0,6	0,8		38,0	37,6	36,3	34,0	31,5	28,9	26,0	23,2	20,0	16,3	12,0	9,8	7,5	2,2	0,7
DTRON3 X 35/90	0,52	0,7		37,0	35,9	35,0	33,0	30,0	26,7	22,7	18,5	13,4	7,6	0,6				
DTRON3 X 45/90	0,6	0,8		45,0	43,0	41,2	38,0	34,2	29,7	24,7	20,0	15,0	9,0	2,5	0,6			
DTRON3 X 35/120	0,6	0,8		38,0	37,6	36,3	34,0	31,5	28,9	26,0	23,2	20,0	16,3	12,0	9,8	7,5	2,2	0,7

ELECTRICAL DATA AND DIMENSIONS

MODEL	ELECTRICAL DATA					A	Ø D	H	DNM	PACKING DIMENSIONS			PACKING VOLUME m³	Q.TY X PALLET	WEIGHT Kg
	POWER INPUT 50 Hz	P1 kW	P2 NOMINAL		In A					L/A	L/B	H			
			kW	HP											
DTRON3 35/90	1 x 220-240 V ~	0,75	0,52	0,7	3,4	185	1" 1/4	651	32	780	230	300	0,05382	15	11,6
DTRON3 45/90	1 x 220-240 V ~	0,93	0,6	0,8	4,2	185	1" 1/4	651	32	780	230	300	0,05382	15	11,6
DTRON3 35/120	1 x 220-240 V ~	0,9	0,6	0,8	4	185	1" 1/4	651	32	780	230	300	0,05382	15	11,6
DTRON3 X 35/90	1 x 220-240 V ~	0,75	0,52	0,7	3,4	185	1" 1/4	651	32	780	230	300	0,05382	15	11,7
DTRON3 X 45/90	1 x 220-240 V ~	0,93	0,6	0,8	4,2	185	1" 1/4	651	32	780	230	300	0,05382	15	11,7
DTRON3 X 35/120	1 x 220-240 V ~	0,9	0,6	0,8	4	185	1" 1/4	651	32	780	230	300	0,05382	15	11,7

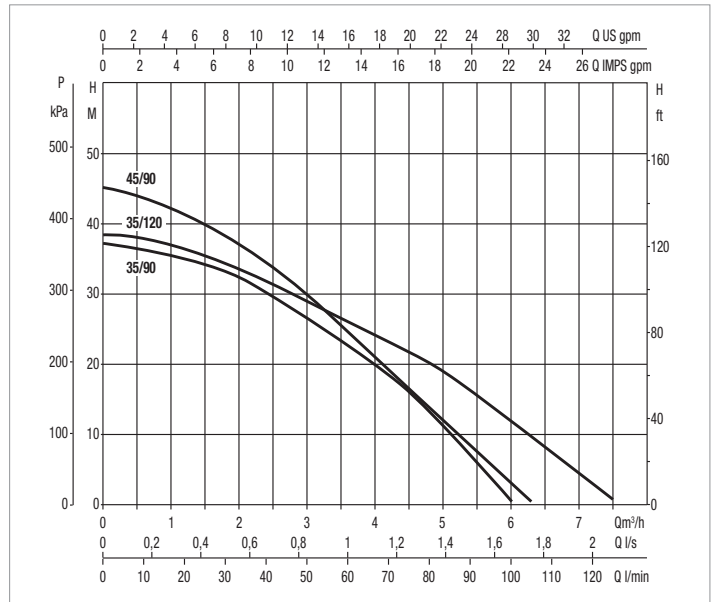
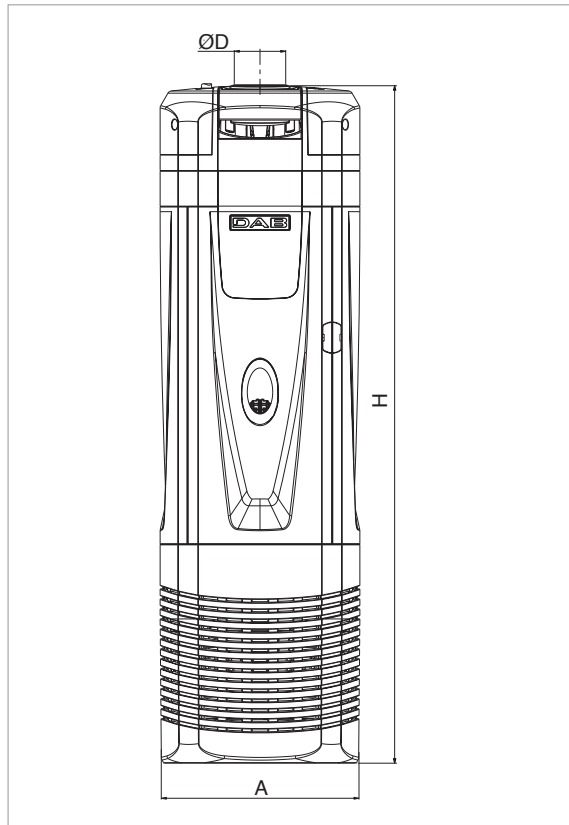

The performance curves are based on kinematic viscosity values = 1 mm²/s and density equivalent to 1000 kg/m³. Curve tolerance according to ISO 9906.

DAB

P U M P S S E L E C T O R



On-line selection tool



DAB PUMPS LTD.

6 Gilberd Court
Newcomen Way
Severalls Business Park
Colchester
Essex
CO4 9WN - UK
salesuk@dwtgroup.com
Tel. +44 0333 777 5010



DAB PUMPS IBERICA S.L.

Calle Verano 18-20-22
28850 - Torrejón de Ardoz - Madrid
Spain
Info.spain@dwtgroup.com
Tel. +34 91 6569545
Fax: + 34 91 6569676



DAB PUMPS SOUTH AFRICA (PTY) LTD

Twenty One industrial Estate,
16 Purlin Street, Unit B, Warehouse 4
Olifantsfontein -1666 - South Africa
info.sa@dwtgroup.com
Tel. +27 12 361 3997



DAB PUMPS BV

*Hofveld 6 C1
1702 Groot Bijgaarden - Belgium
info.belgium@dwtgroup.com
Tel. +32 2 4668353



DAB PUMPS HUNGARY KFT.

H-8800
Nagykanizsa, Buda Ernő u.5
Hungary
Tel. +36 93501700



DAB PUMPS (QINGDAO) CO. LTD.

No.40 Kaituo Road, Qingdao Economic & Technological
Development Zone
Qingdao City, Shandong Province - China
PC: 266500
sales.cn@dwtgroup.com
Tel. +86 400 186 8280
Fax +86 53286812210



DAB PUMPS B.V.

Albert Einsteinweg, 4
5151 DL Drunen - Nederland
info.netherlands@dwtgroup.com
Tel. +31 416 387280
Fax +31 416 387299



DAB PUMPS POLAND Sp. z o.o.

Ul. Janka Muzykanta 60
02-188 Warszawa - Poland
polska@dabpumps.com.pl



DAB PUMPS DE MÉXICO, S.A. DE C.V.

Av Amsterdam 101 Local 4
Col. Hipódromo Condesa,
Del. Cuauhtémoc CP 06170
Ciudad de México
Tel. +52 55 6719 0493



OOO DAB PUMPS

Novgorodskaya str. 1, block G
office 308, 127247, Moscow - Russia
info.russia@dwtgroup.com
Tel. +7 495 122 0035
Fax +7 495 122 0036



DAB PUMPEN DEUTSCHLAND GmbH

Tackweg 11
D - 47918 Tönisvorst - Germany
info.germany@dwtgroup.com
Tel. +49 2151 82136-0
Fax +49 2151 82136-36



DAB PUMPS INC.

3226 Benchmark Drive
Ladson, SC 29456 - USA
info.usa@dwtgroup.com
Tel. 1- 843-797-5002
Fax 1-843-797-3366



DAB PUMPS OCEANIA PTY LTD

426 South Gippsland Hwy,
Dandenong South VIC 3175 - Australia
info.oceania@dwtgroup.com
Tel. +61 1300 378 677